

# SBC - 2408 / 2410 / 2413

## 3 Stage Battery Charger

### User Manual

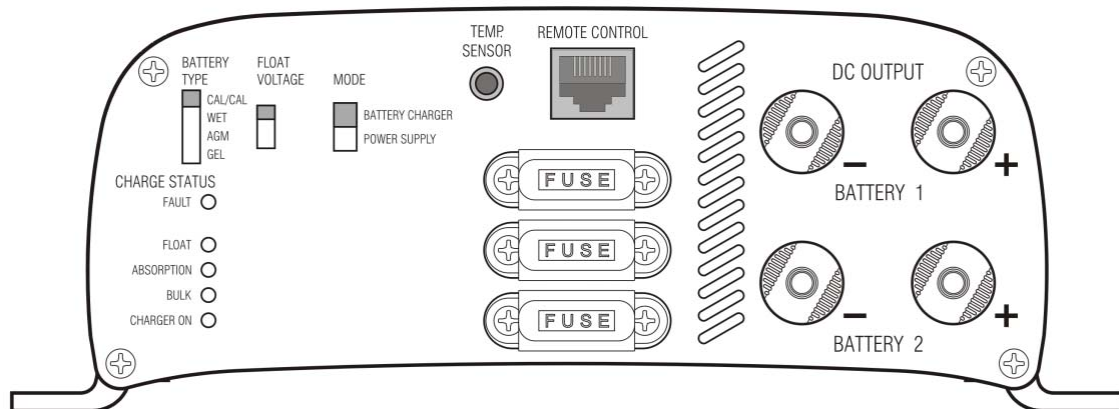

Keep this manual in a safe place for quick reference at all times.

This manual contains important safety and operation instructions for correct use of the battery charger. Read through the manual and pay special attention to the markings and labels of the charger, battery and equipment connected to the battery system.

Pay special attention to these two types of notices used in this manual.

#### **WARNING :**

***Failure to heed this warning may cause injury to persons and damage to Equipment.***

#### **CAUTION :**

***Failure to observe this warning may result in damage to equipment and improper functioning of the Charger.***

#### **WARNING :**

- The charger is designed for in-door use. Protect the charger from ingress of water.
- This charger is made to charge only properly sized lead acid batteries.
- Don't recharging non-rechargeable batteries.
- Charging other types of battery or under-sized lead acid batteries may cause fire or explosion.
- Install the charger in accordance with all local codes
- Do not use the charger if it has been dropped or damaged.
- Do not remove casing of the charger, there is no user –serviceable parts inside.
- Do not charge the battery on boats. Remove the battery and charge on shore.
- Never attempt to charge a frozen battery
- Never attempt to charge a damaged battery.
- Wear protective goggles and turn your face away when connecting or disconnecting the battery.
- Never place the charger on top of a battery .
- Never smoke, use an open flame, or create sparks near battery or charger during normal charging operation as batteries may give out explosive gas.
- Do not charge batteries in an enclosure (box- in) due to possible explosion of entrapped explosive gas.
- Use of accessory not recommended may cause risk of fire, electric shock.
- Disconnect the mains supply before connecting or disconnecting the links to the battery.
- If the charger does not work properly or if it has been damaged ,unplug its AC and DC connection.

#### **CAUTIONS :**

- Refer to battery manufacturer's specific recommended values for battery type settings and float voltage setting.
- Fix the charger to a horizontal solid support via four grooves at the flange of chassis, with four screws or nuts.
- Ensure all ventilation ports are not obstructed for efficient fan cooling, keep loose soft material or paper off at the bottom of the charger.
- During charging, the battery must be placed in a well ventilated area.
- If longer output charging cord is required, make sure the diameter is adequate for the current in given cable length.

## Introduction

Congratulations on purchasing our new 3-Stage (IU0U) Switching Mode Battery Charger.

This battery charger is suitable for wet, sealed (RVLA), calcium-calcium, GEL and AGM in both car (SLI) and deep cycle type of lead acid battery.

It is a “set and forget” automatic charger which can be permanently connected to battery.

These models have dual charge banks for charging two batteries simultaneously.

The special selectable Power Supply Mode allows charging battery with external load.

### Intended Use:

All Automotive, Marine, Mobile Home, Electric Scooters, Golf Carts, Solar, Deep Cycle, UPS Standby, Industrial & Commercial Applications.

## A. Control and Indicators

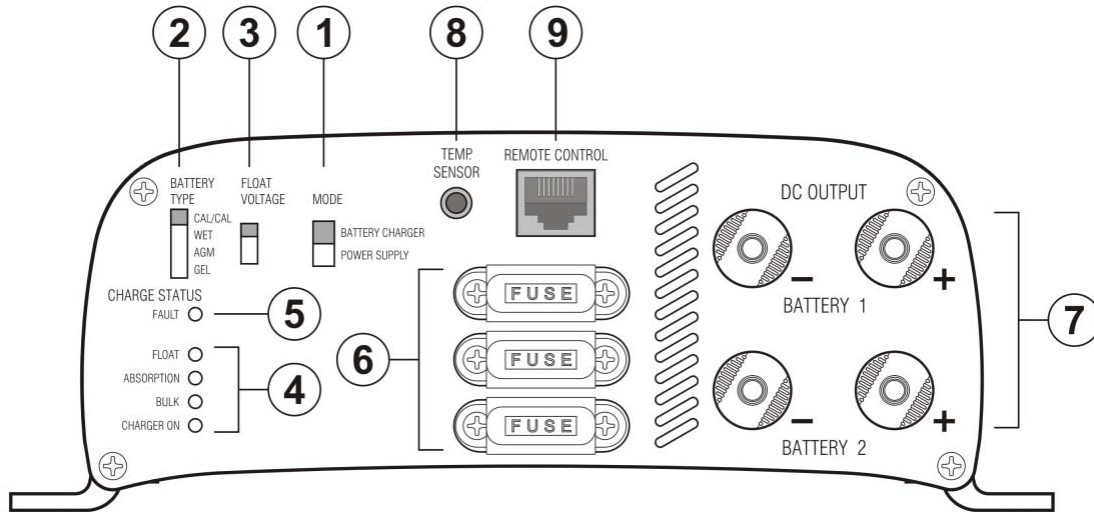

Fig.1

### 1. Battery Charger / Power Supply Selection

Slide Switch to set Charger to 3-Stage Charger or Power Supply Mode (See Section G)

### 2. Battery Type Selection

Slide Switch to set charger for GEL, AGM, Wet and Calcium-Calcium type battery.

### 3. Float Voltage Selection

Slide Switch to set Float Charge voltage to 52.8 / 54.0V / 55.2V.

### 4. Charge Status LED Display

Charger ON LED	: Green – 3-Stage Charger Mode
	Red - Power Supply Mode
BULK LED (Red)	: Bulk Charging with constant max. current
ABSORPTION LED (Orange)	: Absorption charging with preset constant max. voltage.
FLOAT LED (Green)	: Float charging with preset constant voltage

### 5. FAULT LED (Red)

Charger malfunction (See Trouble Shooting)

### 6. Car Blade Fuse

Fuse for reverse polarity protection .

### 7. Charging Banks

Screw Terminals to connect to charging cable.

### 8. Temperature Sensor Socket

Connection to accessory ATS-5120

Sensor to increase / decrease charge voltage at low / high battery temperature .

### 9. Remote Control socket

Connection to optional accessory ABD-4120.

To remote display the charging voltage & charging status and remote control the charger output ON/OFF.

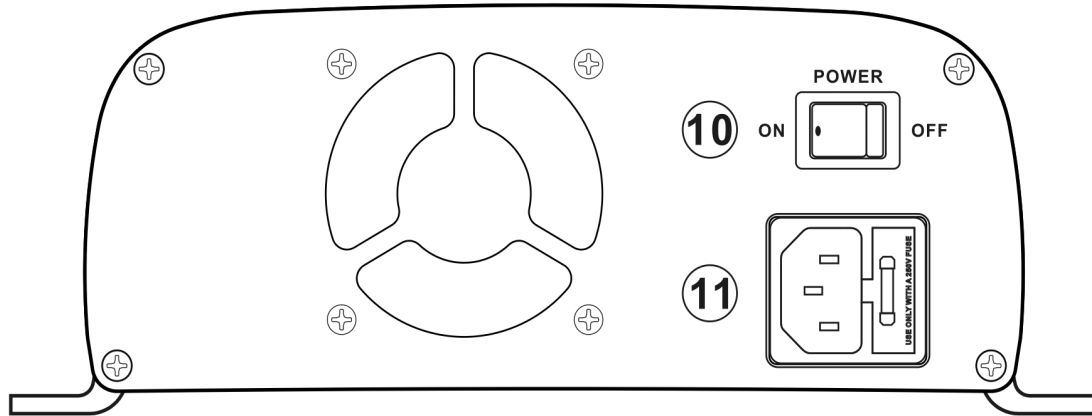

**Fig.2**

**10. Power Switch**

To turn on and off AC power to Charger.

**11. Inlet AC Socket with Fuse Holder**

**B. Battery Type Selection**

AGM/GEL : Sealed type (VRLA) , AGM-GEL , Maintenance Free , Automotive or Deep Cycle lead acid batteries

WET : Flooded Type lead acid batteries (to which water can be added) Automotive or Deep Cycle

Calcium-Calcium : Sealed type (VRLA) Lead Acid batteries with Calcium content Automotive or Deep Cycle

**B1. FLOAT VOLTAGE SELECTION**

These fine tuned selections of float voltages enable the best voltage level for maximum battery life. Choose 55.2V when in doubt or in Power Supply Mode.

Follow the markings on Deep Cycle batteries of the Standby float voltage.

**B2. Recommended Battery Capacity**

The following minimum AH capacities are a generalized suggestion, some batteries can take higher charge current, check with battery manufacturers for charging batteries with smaller capacity.

Charger Model	SBC-2408 , 8A	SBC-2410 , 10A	SBC-2413 , 13A
Battery Capacity	30 AH - 80 AH	30 AH - 100 AH	40 AH - 150 AH

**C. Battery Charger Installation and Connection**

Observe the warnings & safety precautions before rushing to install and operate the charger.

Check battery condition, fill up cells for wet battery, clean battery poles.

Secure the battery charger in a well ventilated place, make sure the mounting surface is flat and without soft covering material or loose paper sheet. The air intake is at the bottom and air outlet at the back. Make sure both intake and outlet are not blocked. Never place charger on top of battery.

Plug in the AC mains and turn on Power Switch, the Charger On LED and the Float LED should be on green indicating Charger is in good order for charging lead acid battery.

Before connecting or disconnecting the charging cable, turn off the Power Switch and unplug AC cord from the mains.

First connect the Red cable to Positive + terminal of charger and the battery Positive + Pole. Then connect the Black cable to the Negative – terminal and the Negative – Pole of the battery.

Make sure all the connections are secured and well tighten up, double check on the correct polarity.

Double check again for correct selection of Slide Switch 1 at Charger Mode, Switch 2 for Battery type and Switch 3 for Float Voltage setting value.

When install in caravans and similar vehicles, the connection to the supply mains is to be in accordance with national wiring rules.

When charging automotive batteries:

- The battery terminal not connected to the chassis has to be connected first. The other connection is to be made to the chassis, remote from the battery and fuel line. The battery charger is then to be connected to the supply mains;
- After charging, disconnect the battery charger from the supply mains. Then remove the chassis connection and then the battery connection.

**Please notice the tightness of the power cables from the power supply to the load. If the cables are not fastened well enough, the total resistance of the connecting cables will increase, resulting in a huge voltage drop between the terminals to the load.**

## D. Normal 3-Stage (IUoU) Charging Operation

The 3-stage IUoU charge algorithm ensures fast, complete and at the same time gentle charging of the lead acid battery.

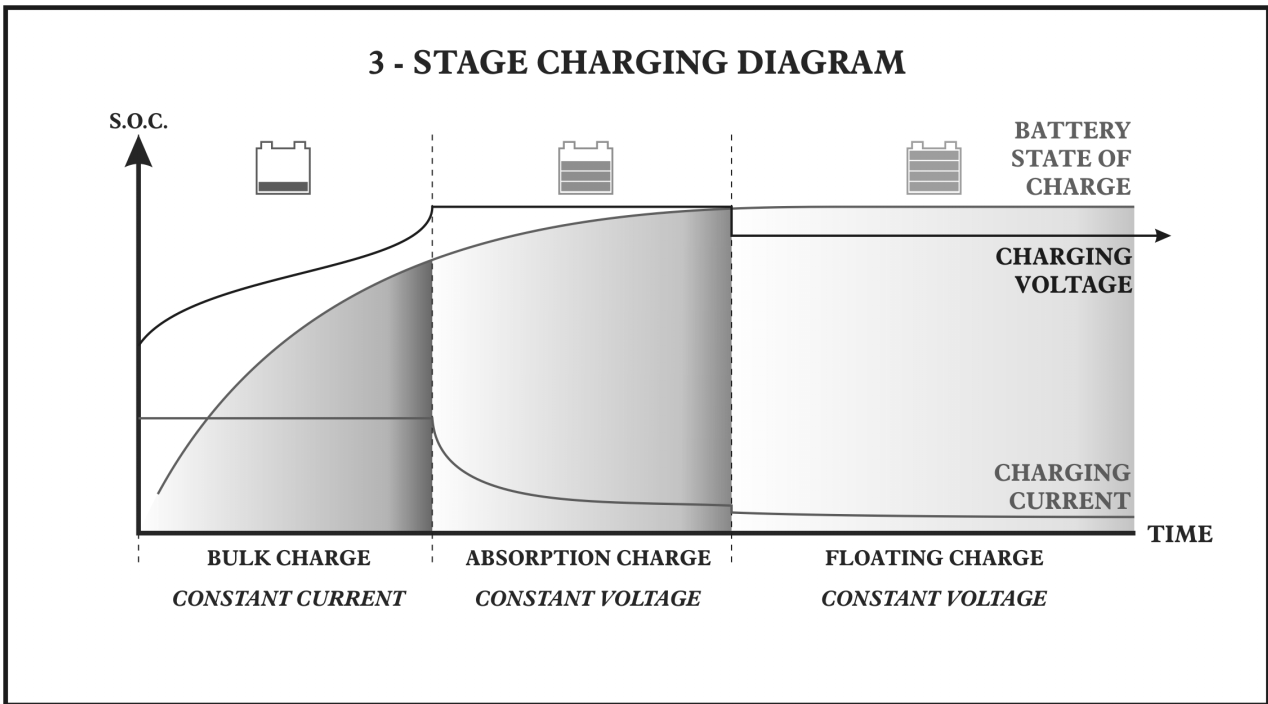

Fig.3

**Stage 1. THE I-PHASE.** The constant current charging, Bulk LED is on.

Normally the battery is charged at constant maximum current until it rises to the selected Absorption voltage level. The charging voltage changes with the battery voltage.

If the initial battery voltage is less than 36V due to deep discharge, the bulk charge current is reduced to half of the maximum until battery voltage rises over 36V.

**Stage 2. THE UO-PHASE .** The constant voltage charging, Absorption LED is on .

Battery Type Selection : Gel : 56.4V / AGM: 57.2V / Wet : 57.6V / Calcium : 62.2V

When the battery voltage rises to the selected Absorption voltage level, the charging switches to Constant voltage charging and battery is over 85% full. The battery is kept at this high voltage while the current reduces gradually to set value at which the charger automatically switches to Float Stage.

**Stage 3. THE UO-PHASE.** The constant voltage charging, Float LED is on.

Float Voltage Selection : 52.8V / 54.0V / 55.2V

In this stage , the battery is full and only takes in the amount of current necessary for maintaining the capacity. The float voltage is preset independently by user according to the type of battery such that battery can be connected permanently to the charger when it is not in use.

## E. Manual Equalization Charging for wet type battery only

Wet lead acid battery requires periodic high voltage charging (about 10% overcharge absorption voltage) to balance the voltage of each cell, reverse the high concentration of electrolyte at the bottom and clear up large sulfate crystals on the plates. You can use the Calcium-Calcium selection to perform the manual equalization by carefully following the battery maker's recommended frequency and duration.

Make sure to manually switch off charger when time is up.

Take special precautions as battery will emit explosive gas during equalization charge.

## F. Dual bank charging

This feature is for caravans, and vehicles with two separate batteries.

The two batteries must be of same chemical make up and type to avoid over and under charging because only one setting of charging profile for both.

Two batteries are charged simultaneously and the battery with the lowest level gets most share of the current in the Bulk charge stage until it is up to the same voltage level of the second battery (battery with higher initial level).

Both batteries will go to the Absorption and the Float Charge at the same time.

## G. Power Supply / 2-Stage Charger Mode (see Fig.4)

At this mode the Charger On (4) LED becomes red color and only Bulk and Float LED will function. The bulk LED will be off when battery is charged to about 80% full.

The 3-stage charger becomes a 2-stage charger or as power supply in this selected mode because 3-stage charger overcharges battery with external load.

This selected mode is intended for use to charge battery with external load such as caravan or other battery and external load combination.

A 2-Stage charger can be used as a combination charger/power supply. An external load can draw current from the charger while the charger is recharging a battery. The charger does not care how much current is being diverted by an external circuit as it switches from Bulk mode (constant current) to Float mode based only on the battery terminal voltage.

However, a 2-Stage charger cannot completely charge the battery when the charger switches from bulk mode to float mode. After switching to float mode, the battery will, in most cases, be about 80% recharged. The battery receives the remaining recharge while in float mode over several days.

It is highly recommended to switch back to the 3-Stage Charger Mode periodically when the external load is disconnected.

Also the external load should not be more than 50% of the max. current of the charger, unless the battery is fully charged up. If the bulk LED is on most of the time then the load is too large.

### G1. As a stand alone power supply

It can also be used as a stand alone power supply without connection to a battery

It will provide a constant voltage according to the selected Float Voltage (52.8/54.0/55.2V) and rated DC current of the charger. However, it is not recommended for high surge load (such as lamp) in stand alone application as the initial high surge current will trigger the overload protection of the power supply.

**Fig.4 Power Supply / 2-Stage Charger Mode Application**

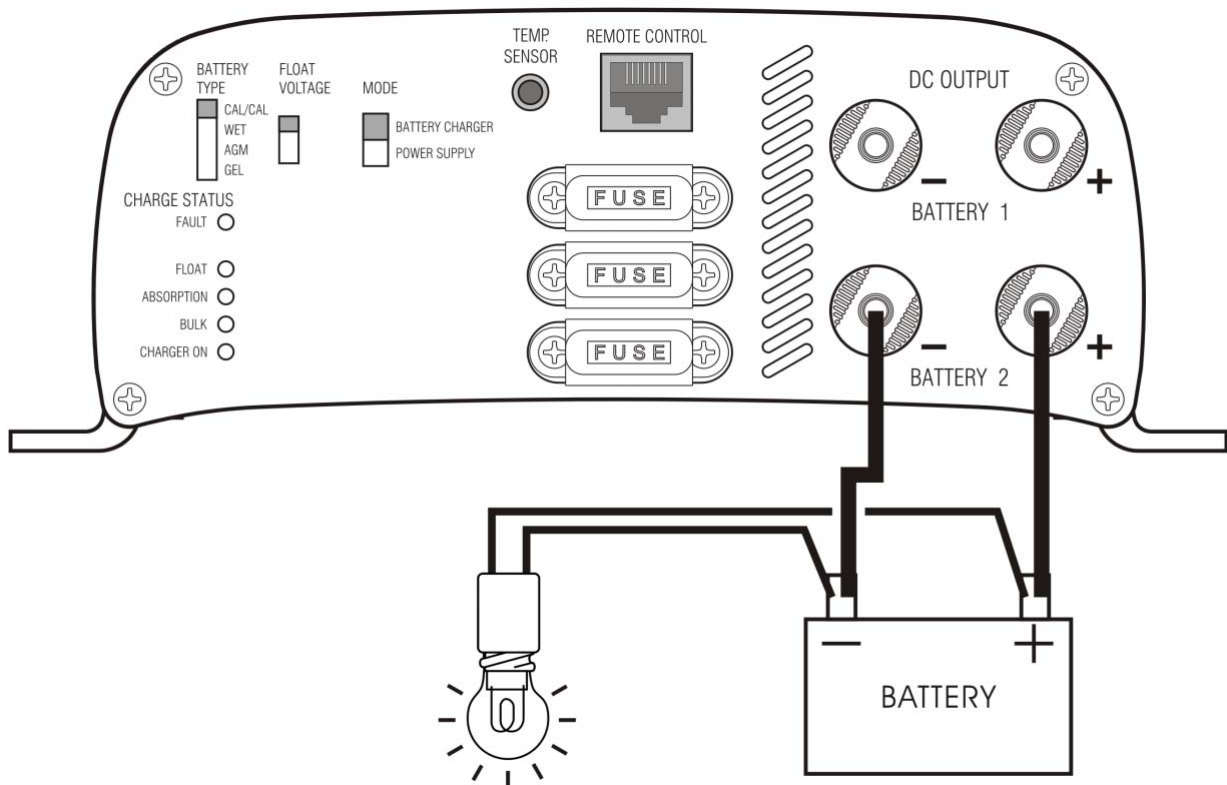

## H. Temperature Sensor

### **Warning :**

**The temperature sensor must be installed at the Negative Terminal of the battery terminal, wrong connection to the Positive Terminal will damage the charger and the sensor .**

The temperature sensor (accessory, ATS-5120) is used to optimal charging over wide ambient temperature range.

Fix the temperature sensor in a position on the battery which is not affected by other cooling or heating source.

Plug in the temperature sensor before switch on the charger to activate the temperature control function, never plug in the charger during charging.

- It is calibrated with battery charger the temperature compensation circuitry at 25°C at the rate of 20mV per °C change.
- A rise of temperature of 1°C will decrease the charging voltage by 20mV
- A decrease of 1°C will increase the charging voltage by 20mV but will stop to increase while the temperature reaches zero°C.
- Temperature compensation can be activated at all charging stage the Bulk, Absorption & Float.

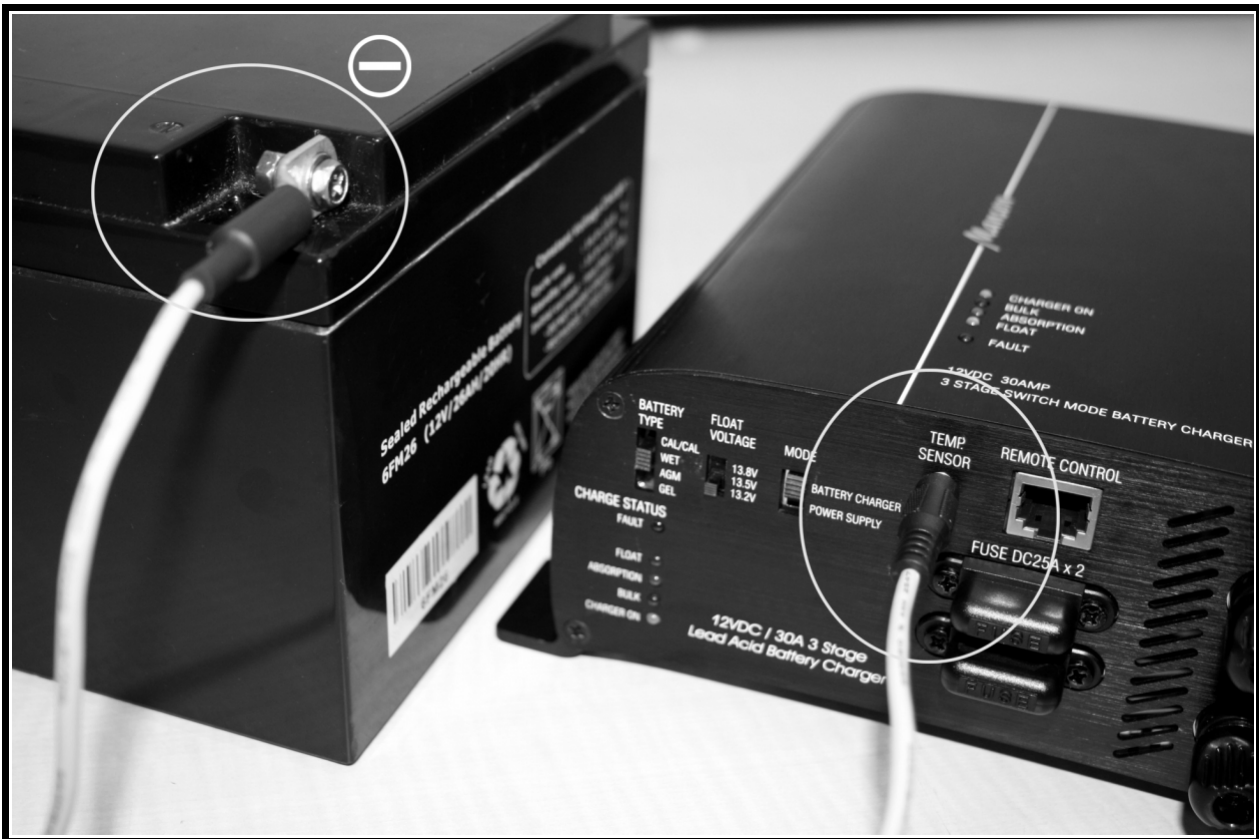

**Fig.5**

## I. Cable Size Selection

Wire Size (AWG)	Area (mm <sup>2</sup> )	Maximum one-way distance (feet) for 2% Voltage loss (48V 8A)	Maximum one-way distance (feet) for 2% Voltage loss (48V 10A)	Maximum one-way distance (feet) for 2% Voltage loss (48V 13A)
10	5.26	57	46	35
8	8.37	90	72	55
6	13.3	145	116	89
4	21.2	228	182	140
2	33.6	360	288	221
1/0	53.5	580	464	356
2/0	67.4	720	576	443
4/0	107	1060	848	652

**Table: Selection of cable size and length versus current**

## J. Trouble Shooting

PROBLEM	INDICATIONS	POSSIBLE CAUSES	SUGGESTED SOLUTION
Charger does not work	Indicator lights not turn on	No AC power AC input socket fuse blown	Check AC connections are correct Replace with correct AC fuse by qualified electrician
No DC output	Charger - On LED is not on, Float and Fault LEDs are on.	Output short circuit Over temperature protection triggered Severe over loading charger Reverse polarity connection	Check DC connections between charger and battery Check air intake vent at bottom of charger is blocked or not. Check charger ambient ventilation . Check battery AH capacity within recommended range Check for correct polarity, replace car blade fuse (6)
Battery does not get full charge	All indicator LED work normally and sequentially	Bad battery connection Battery type select switch in wrong setting Battery capacity too large Ambient temperature too low Battery has damaged cell or battery is too old	Check for loose contact, right cable size, cable integrity Recheck battery type and change to correct battery selection Make sure charger rating matches battery capacity see table (B2) Move battery to a room temperature location, or get an optional temperature sensor Replace battery
Long charging time , float light does not come on even after 20 hours charging time.	Absorption light remains on all the time	Wrong battery type selection eg. charge gel battery with Calcium-Calcium OR Wet type selection Total battery capacity is too high for dual charging Battery temperature too high Battery is defective A load is connected to battery and charger is not in power supply mode.	Check charged battery label and change battery type selection to correct setting. Check battery capacity or charge battery separately Use temperature sensor (optional accessory) Replace battery Change charger Selector Switch (1) to Power Supply Mode.
Bulk LED is on all the time	Bulk light remains on all the time when Charger is in Power Supply Mode, charger ON LED (4) is on red.	The connected load is too large, using most of the current from the charger.	Reduce the load to about 50% of the charger's rating current Or take away the load and set Charger to Battery Charger Mode to fully charge the battery before return back to the power supply setting and load connection.
	Bulk light remains on all the time when Charger is in Battery Charger ON LED (4) is on green.	Wrong battery type selection Battery is excessively depleted and the soft charging is triggered Battery temperature too high	Check charged battery label and change battery type selection to correct setting. Recharge the battery after a day, if bulk light remains after several hours, the battery is most likely damaged and cannot accept charge. Replace battery. Use accessory temperature sensor

## K. Specifications

Model	SBC – 2408	SBC – 2410	SBC - 2413	
Output	Absorption Charge Voltage Selections	GEL : 56.4V ; AGM: 57.2V ; WET : 57.6V ; CALCIUM-CALCIUM : 62.2V		
	Absorption Charge Timer	Limited not over 4hrs		
	Float Charge Voltage Selections	52.8V, 54.0V, 55.2V		
	Battery Charger / Power Supply Selections	Yes	Yes	Yes
	Maximum Output Charging Current (Continuous)	8A	10A	13A
	Recommended Battery Capacity Range	30 – 80AH	30 – 100AH	40 - 150AH
	Soft Start Bulk Charge			
	Battery Voltage to Trigger (cut-in) Soft Start Bulk Charge Mode	<36V		
	Soft Start Bulk Charge Current (Current Limit)	4A	5A	6.5A
	Ripple and Noise (Peak to Peak)	<300mV	<300mV	<300mV
	Efficiency at Maximum Power (100V/230V)	>86/90%	>86/90%	>86/90%
Dual Bank Charging (Battery must be of same type)	Yes	Yes	Yes	
Input	AC Voltage Range	100 – 240V 50Hz~		
	AC Current at Full Load (100V/230V)	5.6/2.5A	7.3/3.1A	9.5/4.1A
Protection	Overload	90-110% Rated Output Current or 50% Rated Output Current (Soft Charge) Protection Type : Constant Current Limiting, recovers Automatically after Fault Condition is Removed.		
	Short Circuit	Recovers Automatically After Fault Condition is Removed		
	Reverse Polarity	Car Blade Fuse		
	Over Temperature	Protection Type: Shut Down		
	OVP Output Over Voltage	Yes		
Cooling	Cooling Method	Thermostatic, Variable Speed Fan		
Indicators	3-Stage Battery Charger / Power Supply Mode	Yes		
	Charge Phase Bulk / Absorption / Float	Yes		
	Fault Mode	Yes		
	AC Power	Yes		
Fuses	AC Fuses at IEC AC Power Socket	T6.3A	T8A	T10A
	DC Car Blade Fuse at Front Panel	15Ax1	15Ax1	20Ax1
Accessories	Remote Temperature Sensor, Cable & Spare Fuses	Yes		
	Remote Control Panel	Optional		
Approvals	Safety : EN 60335	Yes		
	EMC: EN 55014; EMF: EN50366	Yes		
Others	Dimensions and Weight	220x80x200mm ; 2.4kg	220x80x261mm ; 3.0kg	220x80x261mm ; 3.2kg
Remarks	All values are based on the standard ambient temperature 25°C and pressure 0.1Mpa.			